

DOCUMENTS REQUIRED TO MAKE APPLICATION FOR RECREATIONAL VEHICLE PERMIT

**[DUE TO TIME INVOLVED TO PROCESS PAPERWORK - NO APPLICATION OR PERMIT WILL
BE PROCESSED AFTER 4:30 P.M.]**

1. **Application completed. Incomplete applications will be rejected.**
2. Parcel description of property (**property card**) from Property Appraiser's Office or at www.suwanneepa.com. **If property card is in the name of the previous owner, then you MUST provide a copy of the recorded deed proving your ownership of the property, OR (2) have a consent form signed by the previous owner.**
3. **Survey** of property prepared by a land surveyor or engineer registered in Florida. All property stakes shall be in place at the time of application. If a survey is **not** available and it's not in a subdivision you can request an exemption letter from the Zoning Department via email at ronaldm@suwcountyfl.gov.
4. If your property is **LESS** than **5 acres**, **NOT** in a recorded subdivision, **NOT** in a residential zoning district then you will need a deed showing that property was a lot of record prior to **September 9, 1991**.
5. **Site plan** showing **location of residence, driveway, and distance to side property line, septic tank and well and distance from the front, sides and rear of property**. (A-1 district must meet minimum setback requirements of 30 ft. from front property line {any property line fronting a roadway} and 15 ft. from sides and rear property lines.
6. Must provide a copy of **current tag registration (number OR title not sufficient)** for recreational vehicle.
7. Copy of current driver's license **OR** utility bill with current mailing address showing homestead elsewhere.
8. **Must provide letter or other documentation from electric service provider confirming they service the property.**
9. Complete 911 application (attached).
10. Completed owner disclosures if work is being conducted by the **property owners**.
11. If property is in a flood zone, additional information will be needed.
12. **Application process for a new septic tank permit or approval letter for an existing septic tank with Environmental Health (386-362-2708 Ext. 243), must be started BEFORE submitting your building permit application to the building department. These documents must be received from Environmental Health before a building permit will be issued.**
13. The Driveway Application will be completed at the time the permit is issued. **Driveways must be inspected if it has not been inspected within the last year.**
14. You **SHOULD** go over the checklist **PRIOR** to calling for final inspection; failure to do so may result in a reinspection fee of \$35.00. **DUE TO POSSIBLE DUPLICATION OF NAME AND TIME INVOLVED IN LOOKING FOR PERMIT NUMBER. YOU MUST PROVIDE OFFICE PERSONNEL WITH A PERMIT NUMBER WHEN CALLING FOR INSPECTION.**

A change of mind after securing permit will result in an additional charge of \$25.00 administrative costs for reprocessing paperwork.

<u>PERMIT FEE FOR TEMPORARY R.V.</u>	\$300.00 (See pro-rated chart inside)
<u>COUNTY DRIVEWAY PERMIT FEE</u>	\$ 50.00
<u>ASSIGNMENT OF 911 ADDRESS FEE</u>	\$ 30.00
<u>FIRE & SOLID WASTE FEE</u>	(See pro-rated chart inside)

Pro-rata share of assessment for solid waste and fire service **MUST** be paid for the balance of the year.

THESE INSTRUCTIONS ARE FOR THE IDEAL CASE, DEPENDING ON INDIVIDUAL NEED, CIRCUMSTANCES MAY VARY.

RECREATIONAL VEHICLE PERMIT APPLICATION

For Recreational Use Only

SUWANNEE COUNTY BUILDING DEPARTMENT

224 PINE AVENUE, LIVE OAK, FL 32064

(P) 386-364-3407 • (F) 386-364-3754 • www.scpermit.com • permits@suwcountyfl.gov

APPLICANT: _____ PHONE NO. _____

CURRENT ADDRESS: _____

PROPERTY OWNER NAME: _____

ADDRESS: _____

CONTACT EMAIL: _____

LEGAL DESCRIPTION: (as found on the parcel description printout)

Sec. _____ Twp. _____ S Rge. _____ E Tax Parcel No. _____

Lot _____ Subdivision _____

Size _____ Acres

HOW DO YOU GET THERE FROM THIS OFFICE: **You MUST give road numbers and EXACT directions!**

JOB DESCRIPTION: Recreational Vehicle USE: Recreational

RECREATIONAL VEHICLE YEAR/MAKE: _____ SIZE: _____

TAG DECAL NO. _____ DEALER: _____

Electrician: _____ License # _____ Phone: _____

POWER COMPANY: SVEC: _____ FP & L: _____ DUKE: _____

Application is hereby made to obtain a permit to do the work and installations as indicated. I certify that no work or installation has commenced prior to the issuance of a permit and that all work will be performed to meet the standards of all laws regulating construction and zoning in Suwannee County. I certify that the entire foregoing information and site plan is accurate and have read the entire application package and understand its content.

DATE: _____

Signature of Applicant

THIS APPLICATION WILL EXPIRE IN 90 DAYS UNLESS A PERMIT IS ISSUED.

HOW TO APPLY FOR A PERMIT

THESE STEPS ARE FOR PROPERTY NOT LOCATED IN THE FLOODWAY OR FLOODPLAIN.

1. Secure application packet from the Building Department.
2. Return all completed forms and required documentation listed on the cover page to the Building Department. (Including driveway application, 911 addressing form)
3. After Zoning Compliance Approval is granted, the Building Department will email the Zoning Compliance approval to the Environmental Health Department. **You must apply for a septic permit before your permit can be issued.**
4. The Building Department will submit the 911 addressing form and driveway application to the appropriate departments. Those departments return the results to the building department.
5. Complete improvements and call the Building Department for inspection (**You must have your permit number to request inspection**) at 386-364-3407 between the hours of 8:00 a.m. and 4:30 p.m., Monday through Friday.
6. If improvements pass inspection and the final approval of driveway has been received from Public Works Department, the fire and solid waste tax assessment is paid, and final approval on septic has been received from Environmental Health Department, the power company you provided us with will be notified to release power to dwelling.

NOTE: THERE WILL BE A \$35.00 REINSPECTION FEE CHARGED IF THE SCHEDULED INSPECTION IS NOT READY AT THE REQUESTED TIME. SUBSEQUENT REINPSECTION FEES WILL BE \$50.00 FOR ADDITIONAL INSPECTIONS.

RECREATIONAL VEHICLE QUICK CHECK LIST

1. POST PERMIT ON SITE.
2. WATER WELL INSTALLED AND ELECTRICAL RUN IN SCHEDULE 40 CONDUIT AT WELL AND POLE SITE. ANY CONDUIT ABOVE 18 INCHES TO 8 FEET ABOVE GROUND SHOULD BE SCHEDULE 80.
3. SEPTIC TANK INSTALLED AND APPROVED BY STATE INSPECTOR – WASTE LINE RUN TO TRAILER SITE, WASTE LINE SEALED AT TANK WITH RUBBER GROMMET AND SHOULD HAVE CLEAN OUT PLUG ADAPTER AT CAMPER FOR INSPECTION. ENVIROMENTAL HEALTH DEPARTMENT 386-339-6091.
4. POWER POLE INSTALLED (**100 amp-max**) AND ALL ELECTRICAL HOOKUPS WITH APPROVED PLUG-IN RECEPTACLES FOR TRAVEL TRAILER AND ALL 120 VOLT RECEPTACLES TO BE GFI PROTECTED. **ALL** ELECTRICAL IN SCHEDULE 40 CONDUIT IS REQUIRED TO MAINTAIN A DEPTH OF 18 INCHES, IF BURIED WIRES ARE NOT IN CONDUIT (DIRECT BURIAL) THEY MUST BE TYPE **UF** OR **USE** AND BURIED NOT LESS THAN 24 INCHES DEEP. (WHEN RUNNING WATER LINE IN SAME DITCH AS ELECTRICAL LINE, INSTALL WATER LINE 6 TO 8 INCHES ABOVE ELECTRICAL LINE ON MOUND SPACED EVERY 10 FEET APART, AND **LEAVE DITCH OPEN FOR INSPECTION.**
5. HOSE-BIB WITH ANTI-SYPHON VALVE AND CUT OFF VALVE INSTALLED AT TRAVEL TRAILER AND APPROVED TRAVEL TRAILER HOSE. **ALL** WATER LINES MUST BE BURIED A MINIMUM OF 12 INCHES UNDER GROUND, AND **DITCH LEFT OPEN FOR INSPECTION.**
6. 911 ADDRESS MUST BE POSTED AT THE ENTRANCE OF DRIVEWAY.
7. DRIVEWAY MUST BE APPROVED BY THE COUNTY ROAD DEPARTMENT (386-362-3992).
8. SEPTIC MUST BE APPROVED BY ENVIRONMENTAL HEALTH DEPARTMENT (386-339-6091)
9. IF YOU ARE LOCATED IN A FLOODZONE YOU WILL NEED AN ELEVATION LETTER STATING THE ELECTRICAL SERVICE IS AT BASE FLOOD OR HIGHER BY A STATE OF FLORIDA SURVEYOR.
10. IF THE TRAVEL TRAILER IS TO BE PARKED FOR ANY LENGTH OF TIME, IT SHOULD BE BLOCKED, ANCHORED AND STRAPPED AT ALL FOUR CORNERS. IF YOU ARE IN A FLOOD AREA IT MUST REMAIN ROAD READY.
11. A 24-HOUR NOTICE IS REQUIRED TO SCHEDULE A FINAL INSPECTION. YOU MUST PROVIDE OFFICE PERSONNEL WITH A PERMIT NUMBER WHEN CALLING FOR INSPECTION.

**FAILURE OF ANY OF THE ABOVE WILL RESULT IN A
\$35 REINSPECTION FEE**

ANY FURTHER QUESTIONS, PLEASE CONTACT THE BUILDING DEPARTMENT AT
386-364-3407, 386-364-1997, OR 386-208-1606.

I UNDERSTAND THAT ACCURATE MEASUREMENTS AND NORTH, SOUTH, EAST, WEST DIRECTIONS ARE INTEGRAL PARTS OF MY SITE PLAN WHICH WILL BE USED TO DETERMINE SETBACKS FOR ZONING COMPLIANCE. I ALSO UNDERSTAND THAT IF INSUFFICIENT OR INCORRECT INFORMATION IS SUPPLIED IT WILL CREATE A DELAY IN THE ISSUANCE OF A BUILDING PERMIT.

EXAMPLE SITE PLAN FORM
SUWANNEE COUNTY BUILDING DEPARTMENT

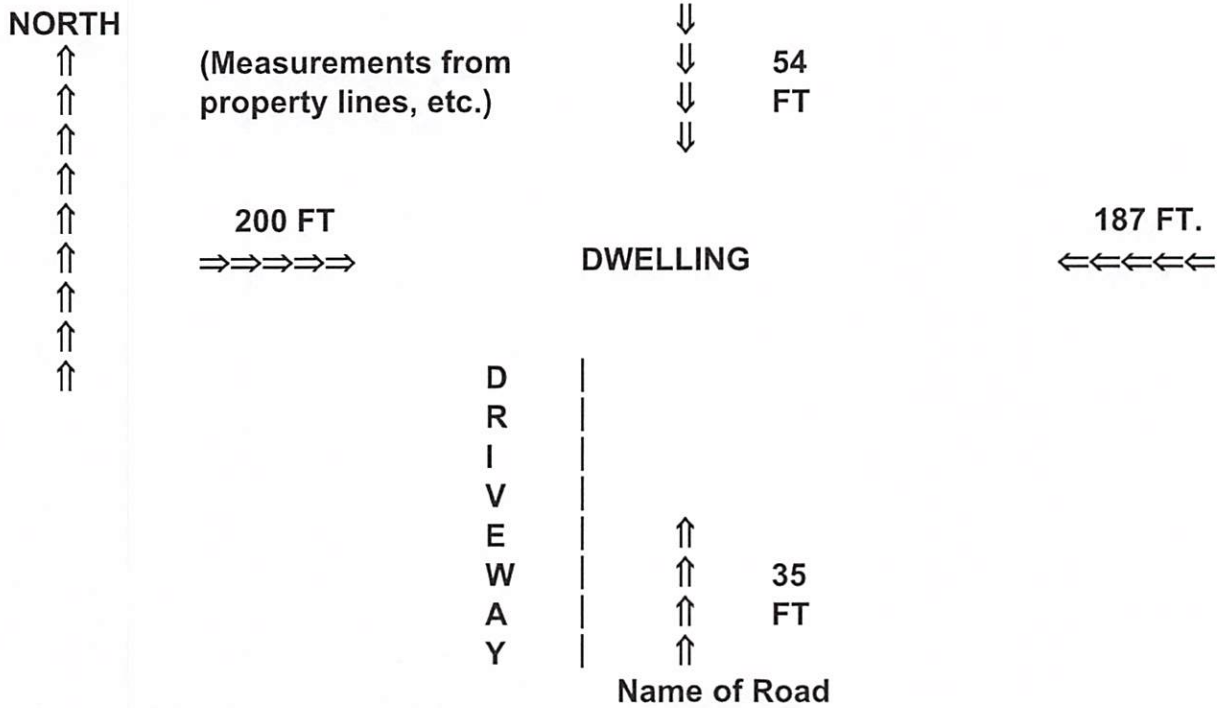

Site Plan preferred to be on survey or GIS map obtain from Property Appraiser Website. www.suwaneepa.com

ITEMS THAT MUST BE ON THE FORM

- 1) STREET & ROAD NUMBERS (EXAMPLE – 56TH STREET)
- 2) ALL BARNs, & ALL OTHER BUILDINGS & SHEDS
- 3) DRIVEWAYS & ENTRANCEWAYS TO PROPERTY, INCLUDING DISTANCE TO SIDE PROPERTY LINE
- 4) MEASUREMENTS FROM ALL STRUCTURES, WELL, POWER POLE & SEPTIC TANK FROM PROPERTY LINE
- 5) MUST HAVE NORTH, SOUTH, EAST & WEST LOCATION ON PLAN
- 6) SETBACKS & DIRECTION FROM ROADWAY
- 7) SITE PLAN MUST BE COMPLETED, SIGNED AND DATED PRIOR TO BRINGING IT BACK TO THE OFFICE.

PLAN DRAWN BY:

JOHN DOE
SIGNATURE

01/01/00
DATE

SUWANNEE COUNTY BUILDING DEPARTMENT
224 PINE AVE
LIVE OAK, FL 32064
PHONE: 386-364-3407

Recreational Vehicle Permit Acknowledgment

Permit: _____

I _____ agree to the land development regulations for a Recreational Vehicle Permit and understand that I will have to renew this permit every January each year if I am the property owner.

1. Owners must demonstrate a permanent primary residence in another location.
2. Permit shall be for the use of the owner(s) of the property. No commercial or rental use.
3. Occupancy is limited to 6 months in a calendar year.
4. Property is limited to (1) RV site. No other RV's may be connected or stored on the permitted site.
5. RV must obtain permits for and be connected to Septic, Potable Water, and Electrical Service.
6. RV permit shall be renewed on an annual basis. RV permit and any subsequent renewal shall be posted in a weatherproof housing at the electrical service for follow-up inspections.
7. RV's shall remain road-ready and attached to utilities by quick disconnects. No blocking or removal of axles.
8. RV permit shall become void when a residential dwelling unit is placed on the property.
9. If a property with an existing RV permit issued prior to February 21, 2023, is found to be in Code Violation, any previous RV permit issuance shall become void. The property owner shall obtain a new RV permit and be subject to all requirements of this section.

Recreational Vehicles may be occupied for short-term durations while visiting family or friends, not to exceed fourteen (14) consecutive days when visiting premises that provide adequate toilet facilities.

Except as provided in these Land Development Regulations, it shall be unlawful to occupy, live in, dwell in or reside in any recreational vehicle in the County.

Property Owner

Date

Building Department Representative

**SUWANNEE COUNTY
E-911 NEW ADDRESS NUMBER REQUEST**

APPLICANT: _____

PERMIT #: _____

Beginning June 6, 2001, there will be a \$30.00 charge for assignment of a new 911 Address (instituted by the Board of County Commissioners, Suwannee County on 6/5/01).

I UNDERSTAND THAT A REQUIREMENT OF MY OBTAINING A 911 ADDRESS IS DEPENDENT UPON MY COMPLETE COMPLIANCE WITH THE FOLLOWING INSTRUCTIONS:

- 1. I will provide complete driving instructions to my new site that this permit is being acquired for, using the Building Department as the beginning point. I will include roadway numbers and describe all turns by either left or right. Please provide this information in the space below:**

- 2. I will be required to denote the four (4) corners of the proposed structure with distance to property lines and show the entrance of the driveway including the road name that you will enter from on the site plan submitted to the Building Department. If proper measurements are not given I understand it will delay the assignment of my 911 address.**

- 3. I will provide one or more telephone number(s) at which I can be contacted, both daytime and evening:**

Day: _____

Evening: _____

IF YOUR SITE PLAN MEASUREMENTS IS NOT SUFFICIENT YOUR ADDRESS & CERTIFICATE OF OCCUPANCY WILL BE DELAYED.

I UNDERSTAND THAT BY SIGNING THIS DOCUMENT I AM GRANTING PERMISSION FOR THE 911 ADDRESSING TECH TO MAKE A SITE VISIT ON MY PROPERTY IF NEEDED FOR THE PURPOSE OF 911 ADDRESS ASSIGNMENT.

Request Submitted By:

Signature

Date

Your new 911 Address will be assigned based on measurements obtained from your site plan and will be available within three (3) business days from the receipt of the application and fee. The 911 Address is not issued to the individual, but to the dwelling being placed on this parcel, and may not be moved to another location.

DRIVEWAY APPLICATION

**SUWANNEE COUNTY PUBLIC WORKS DEPARTMENT
13150 – 80TH TERRACE, LIVE OAK, FL 32064
PHONE (386) 362-3992**

FEE: \$50.00

If your driveway access is off a State Roadway, please advise our office personnel. You will be required to contact Florida Department of Transportation for your driveway approval. (State Roads are as follows: 27, 51, 90, 129, 247, 49 SOUTH OF 27). **POWER WILL NOT BE RELEASE BY THE BUILDING DEPARTMENT UNTIL YOUR DRIVEWAY HAS BEEN APPROVED BY FDOT.**

DRIVEWAY REQUIREMENTS

POWER WILL NOT BE RELEASE BY THE BUILDING DEPARTMENT UNTIL YOUR DRIVEWAY HAS BEEN APPROVED BY THE COUNTY PUBLIC WORKS DEPARTMENT.

When applying for a building permit, a form for the County Public Works Department must be completed for the Public Works Department to inspect your driveway to see what improvements must be made, if any. Please put stakes at the location of the proposed driveway entrance.

You must provide a printout showing the legal description of property and ownership from the property appraiser's office/website (suwanneepa.com). If it shows in the name of the previous owner then you **MUST** (1) provide a copy of the recorded deed proving your ownership of the property, or (2) have a consent form signed by previous owner.

The Public Works Department will contact you as to the changes that must be made, if any. Please be sure to provide a current phone/fax number & email for them to contact you, otherwise there may be a delay.

It is your responsibility to make the improvements required by the Public Works Department and contact them directly (386-362-3992) to make a final inspection once improvements have been made.

After the Public Works Department has approved the entrance of your driveway, they will notify the Building Department.

SUWANNEE COUNTY PUBLIC WORKS DEPARTMENT
13150 - 80TH TERRACE, LIVE OAK, FL 32064
386/362-3992

Fax # _____

Permit # _____

DRIVEWAY PERMIT APPLICATION
FEE: \$50.00

IF YOUR DRIVE ACCESS COMES OFF ONE OF THE FOLLOWING STATE ROADS PLEASE ADVISE OFFICE PERSONNEL, IT WILL BE NECESSARY FOR YOU TO FILE AN APPLICATION WITH FLORIDA DEPARTMENT OF TRANSPORTATION – 27, 51, 90, 129, 247, 49 SOUTH OF 27

APPLICANT: _____ PHONE #: _____

CURRENT ADDRESS: _____

CONTACT EMAIL: _____ FAX #: _____

PROPERTY OWNER: NAME: _____

ADDRESS: _____

LEGAL DESCRIPTION:

Sec. _____ Twp. _____ S Range _____ E Tax Parcel No.: _____

Lot _____ Subdivision _____

Size _____ Acres Other Dwellings _____

EXACT DRIVING DIRECTIONS FROM MAJOR ROAD LEAVING LIVE OAK TO SITE USING ROAD NUMBERS:

Job Description _____ Use _____

Lot Frontage: _____ Ft. Number of Driveways: _____

Application is hereby made to inspect a driveway(s) to access a "County Maintained Road" only.

Date

Signature of Applicant

To be completed by County Public Works Department

Culvert Required: _____ Size: _____ "Corrugated Metal Culvert with Concrete Mitered Ends"

Apron Required: _____ Width: _____ "Concrete"

Limerock Required: _____ Level & Cap with **6 inches** of limerock, from edge of road to property line

Ditch Fill Required: _____ Width: _____ Depth: _____ Length: _____

Disapproved for the following reasons: _____

APPLICANT MUST CALL PUBLIC WORKS DEPARTMENT at (386) 362-3992 FOR "REINSPECTION" AFTER COMPLETION OF THE ABOVE-MENTIONED REQUIRED MODIFICATIONS. DRIVEWAY MUST BE INSTALLED AND INSPECTED PRIOR TO OCCUPANCY OF STRUCTURE OR NOTIFICATION TO THE POWER COMPANY FOR ELECTRICAL SERVICE.

Approved "As Is": _____
Final Approval (improvements completed): _____

Date

Supervisor of Driveway Inspection
Suwannee County Public Works Department

TYPICAL REQUIREMENTS FOR DRIVEWAYS NOT REQUIRING CULVERTS

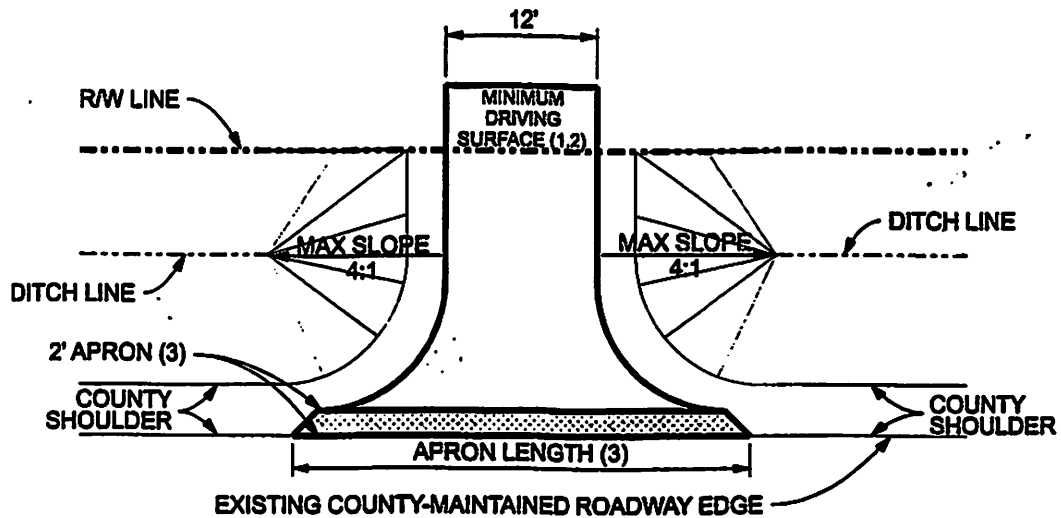

PLAN VIEW

NOTES:

1. DRIVEWAY SURFACE TO BE A MINIMUM WIDTH OF 12'
2. MINIMUM REQUIREMENTS FOR DRIVING SURFACE SHALL BE STABILIZED WITH 6" OF CRUSHED LIMEROCK (COMPACTED) OR OTHER APPROVED MATERIAL.
3. CONCRETE APRON REQUIRED ADJACENT TO PAVED ROADWAYS. APRON SHALL BE 2' WIDE AND 6" THICK. LENGTH TO BE DETERMINED BY PUBLIC WORKS DEPARTMENT
4. FILL AREA SIDE SLOPES SHALL NOT BE STEEPER THAN 4:1

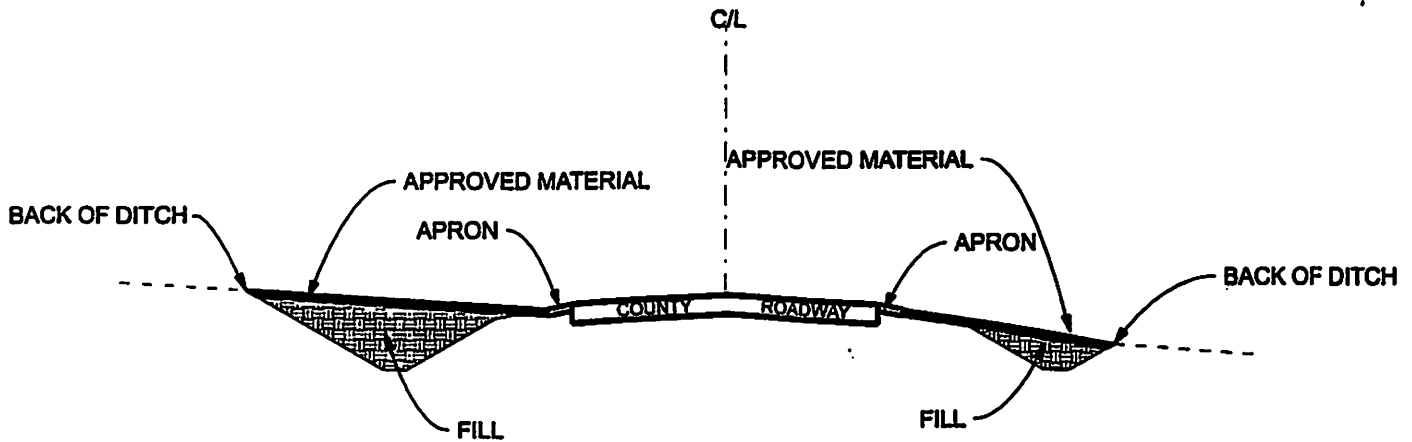

SECTION VIEW

NOTES:

1. TOP 6" OF FILL TO BE CRUSHED, COMPACTED LIMEROCK OR OTHER APPROVED MATERIAL
2. CONCRETE APRONS REQUIRED ADJACENT TO PAVED ROADWAYS, AND EACH IS TO BE 2' WIDE, 6" THICK AND LENGTH TO BE DETERMINED BY PUBLIC WORKS DEPARTMENT
3. DITCH FILL WIDTH WILL BE DETERMINED BY PUBLIC WORKS. FILL AREA SIDE SLOPES SHALL NOT BE STEEPER THAN 4:1.

TYPICAL REQUIREMENTS FOR DRIVEWAYS REQUIRING CULVERTS

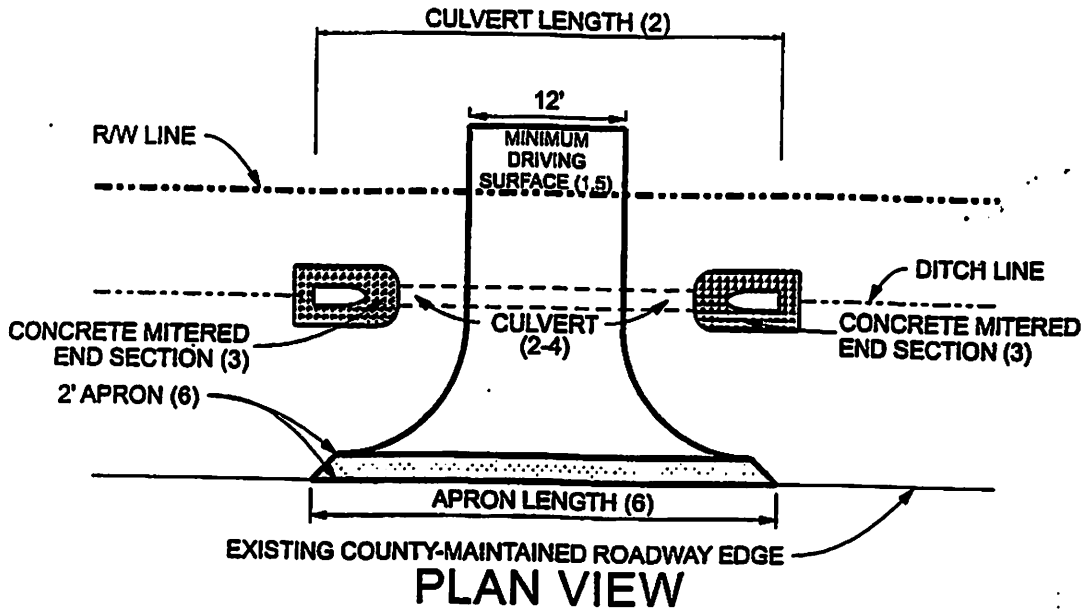

NOTES:

1. DRIVEWAY SURFACE TO BE A MINIMUM WIDTH OF 12'
2. CULVERT LENGTH AND DIAMETER TO BE DETERMINED BY PUBLIC WORKS DEPARTMENT
3. CONCRETE ON MITERED ENDS (M.E.S.) SHALL BE CONSTRUCTED TO A MINIMUM OF 6" THICK AND MUST BE 2' IN WIDTH AROUND THE PERIMETER OF THE CULVERT OPENING - SEE ATTACHED M.E.S. DETAIL
4. MINIMUM COVER ON TOP OF CULVERT SHALL BE 6"
5. MINIMUM REQUIREMENTS FOR DRIVING SURFACE SHALL BE STABILIZED WITH 6" OF CRUSHED LIMEROCK (COMPACTED) OR OTHER APPROVED MATERIAL
6. CONCRETE APRON REQUIRED ADJACENT TO PAVED ROADWAYS. APRON SHALL BE 2' WIDE AND 6" THICK. LENGTH TO BE DETERMINED BY PUBLIC WORKS DEPARTMENT
7. FILL AREA SIDE SLOPES SHALL NOT BE STEEPER THAN 4:1
8. culvert must be corrugated metal.

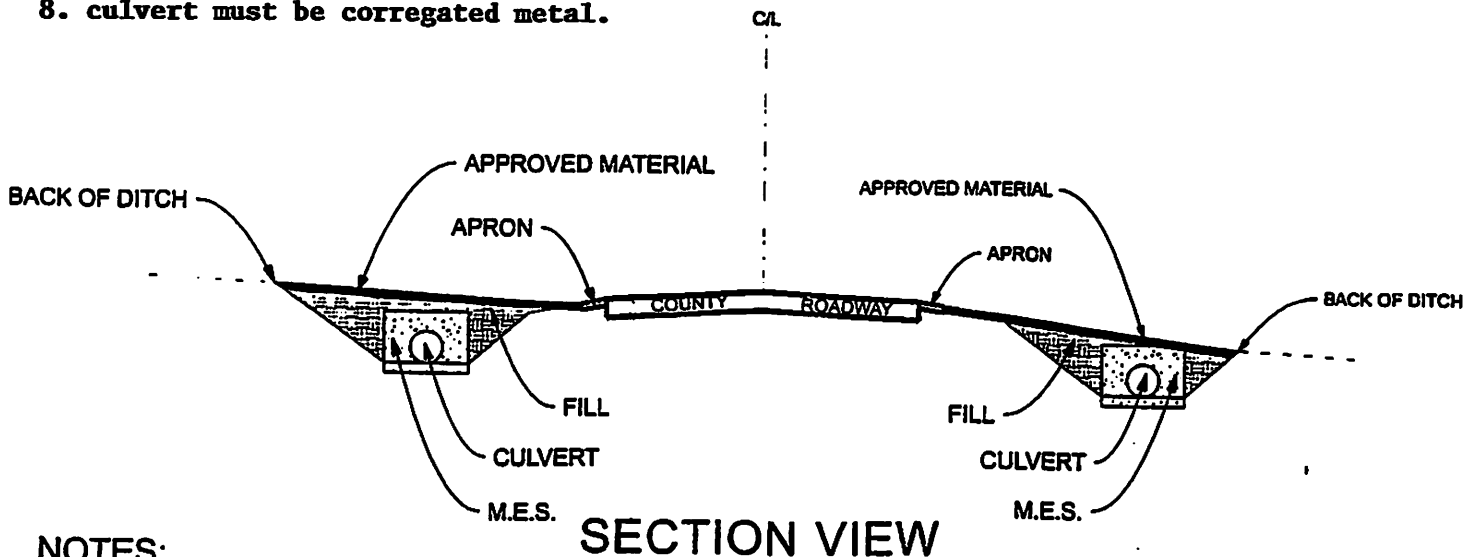

NOTES:

1. TOP 6" OF FILL TO BE CRUSHED, COMPACTED LIMEROCK OR OTHER APPROVED MATERIAL
2. CONCRETE APRONS REQUIRED ADJACENT TO PAVED ROADWAYS, AND EACH IS TO BE 2' WIDE, 6" THICK AND LENGTH TO BE DETERMINED BY PUBLIC WORKS DEPARTMENT
3. DITCH FILL WIDTH WILL BE DETERMINED BY PUBLIC WORKS. FILL AREA SIDE SLOPES SHALL NOT BE STEEPER THAN 4:1.
4. MINIMUM COVER ON TOP OF CULVERT SHALL BE 6"

TYPICAL REQUIREMENTS FOR MITERED END SECTIONS (MES)

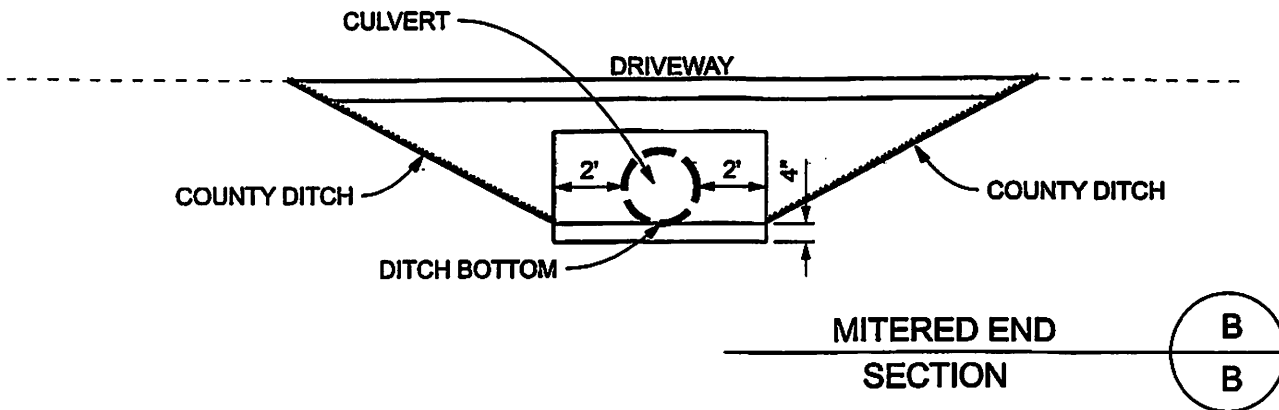
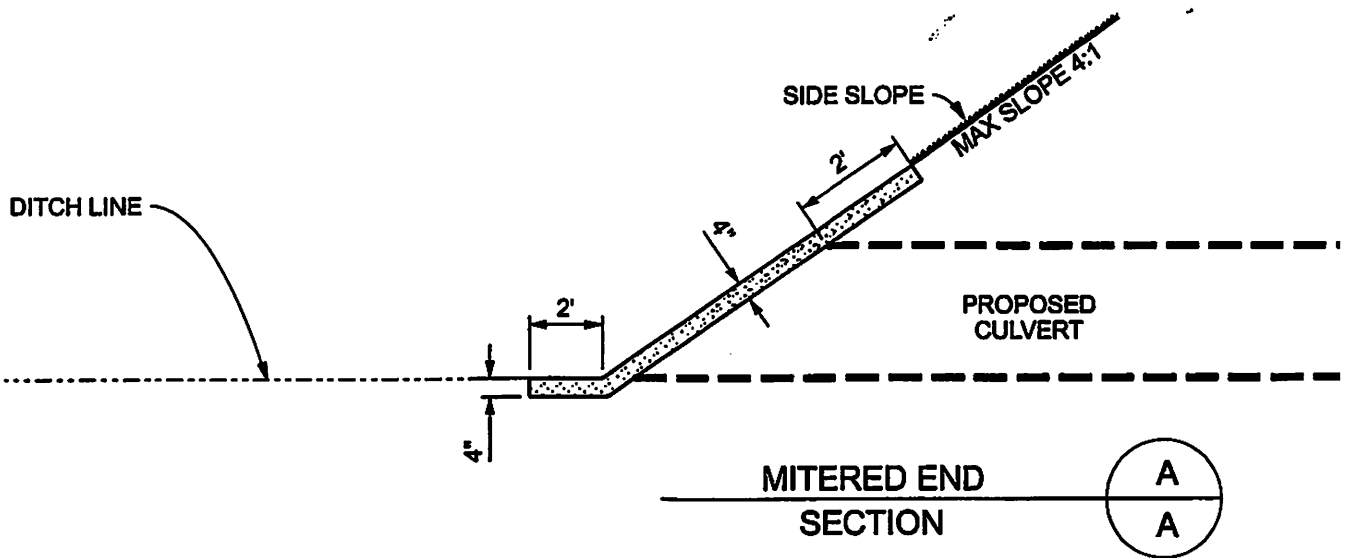
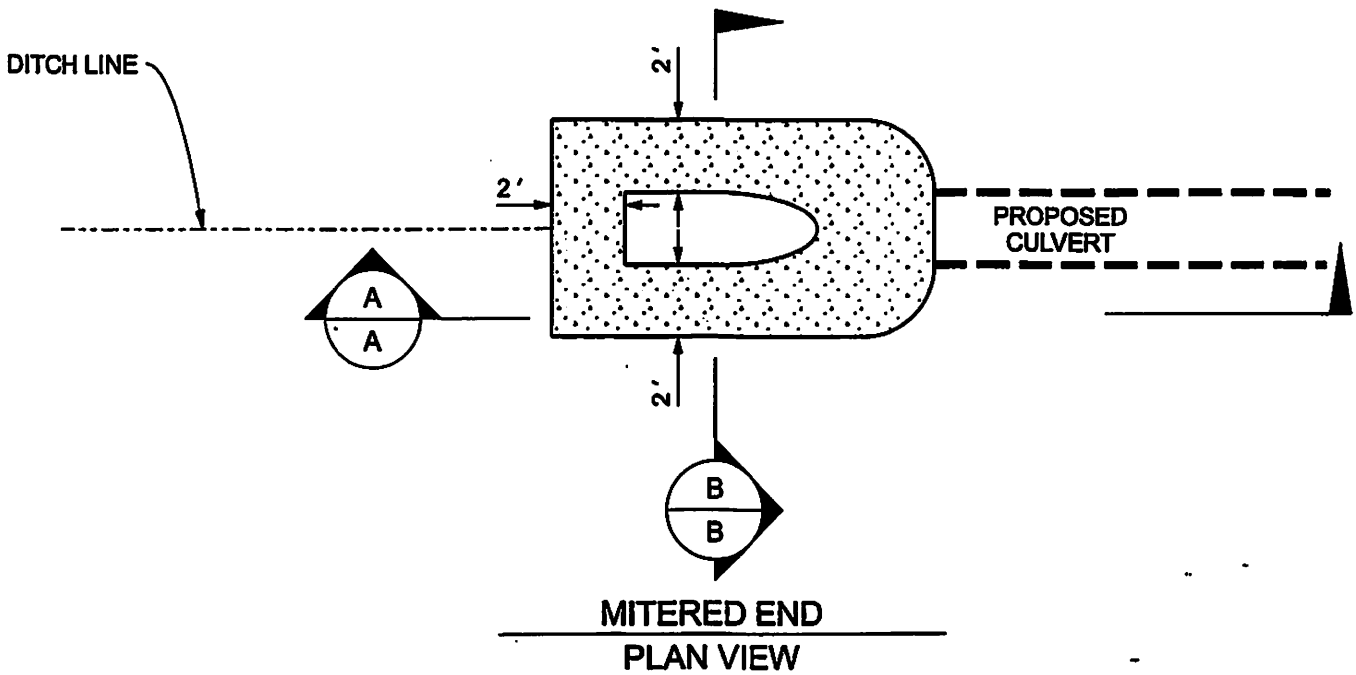

**SUWANNEE COUNTY BUILDING DEPARTMENT
224 PINE AVENUE
LIVE OAK, FL 32064
PHONE: 386/364-3407**

Beginning December 08, 2023 a service charge was placed on all permits for habitable dwellings. This service charge represents a pro-rata portion of the Assessments based on the calendar year. This service charge is due, and **MUST** be paid before final power authorization can be released to the power company.

The rates (effective 12/08/2023) for the Urban and Rural Districts are as follows:

Month	Res. Fire Ass.	Solid Waste Ass.	Total
January	\$ 120.00	\$ 235.00	\$ 355.00
February	\$ 110.00	\$ 215.42	\$ 325.42
March	\$ 100.00	\$ 195.84	\$ 295.84
April	\$ 90.00	\$ 176.26	\$ 266.26
May	\$ 80.00	\$ 156.68	\$ 236.68
June	\$ 70.00	\$ 137.10	\$ 207.10
July	\$ 60.00	\$ 117.52	\$ 177.52
August	\$ 50.00	\$ 97.94	\$ 147.94
September	\$ 40.00	\$ 78.36	\$ 118.36
October	\$ 30.00	\$ 58.78	\$ 88.78
November	\$ 20.00	\$ 39.20	\$ 59.20
December	\$ 10.00	\$ 19.62	\$ 29.62

This service charge was enacted by the County on Dec. 4, 1990, by Resolutions 90-58, & 90-59 and is intended to help defray the costs of fire protection and solid waste services for the remainder of the year. The current fees are to be paid at the Building Department office. You (the property owner) will be billed for these services in all subsequent years in November when the property tax notices are sent out.

Commercial Fire Assessment Fees are .12 per square foot for 12-month period (decreases every month thereafter)

FORMS/SCFEE

SUWANNEE COUNTY BUILDING DEPARTMENT
224 Pine Ave., Live Oak, FL 32064
Phone 386-364-3407

CONTRACTORS' ADDENDUM TO RECREATIONAL VEHICLE

Building Permit No. _____ Date: _____

Owner(s) Name: _____

Sec. _____ Twp. _____ Rge. _____ Tax Parcel #: _____

Lot #: _____ Block _____ Subdivision _____

I hereby certify that the following subcontractors will be used on the above referenced job.

CONTRACTOR	LICENSE NO.
ELECTRICAL: _____	_____

Signature

Subcontractors must Sign prior to issuance of permit

SUWANNEE COUNTY BUILDING DEPARTMENT
224 Pine Ave., Live Oak, FL 32064
386/364-3407

Owner Electrical Disclosure Statement for Permit # _____
(According to Florida Statute 489.503)

An owner of property making application for permit, supervising, and doing the work in connection with the construction, maintenance, repair, and alteration of and addition to a single-family or duplex residence for his or her own use and occupancy and not intended for sale or an owner of property when acting as his or her own electrical contractor and providing all material supervision himself or herself, when building or improving a farm outbuilding or a single-family or duplex residence on such property for the occupancy or use of such owner and not offered for sale or lease, or building or improving a commercial building with aggregate construction costs of under \$75,000 on such property for the occupancy or use of such owner and not offered for sale or lease. In an action brought under this subsection, proof of the sale or lease, or offering for sale or lease, of more than one such structure by the owner-builder within 1 year after completion of same is prima facie evidence that the construction was undertaken for purposes of sale or lease. This subsection does not exempt any person who is employed by such owner and who acts in the capacity of a contractor. For the purpose of this subsection, the term "owner of property" includes the owner of a mobile home situated on a leased lot. To qualify for exemption under this subsection, an owner shall personally appear and sign the building permit application and must satisfy local permitting agency requirements, if any, proving that the owner has a complete understanding of the owner's obligations under the law as specified in the disclosure statement in this section. If any person violates the requirements of this subsection, the local permitting agency shall withhold final approval, revoke the permit, or pursue any action or remedy for unlicensed activity against the owner and any person performing work that requires licensure under the permit issued.

State law requires electrical contracting to be done by licensed electrical contractors. You have applied for a permit under an exemption to that law. The exemption allows you, as the owner of your property, to act as your own electrical contractor even though you do not have a license. You may install electrical wiring for a farm outbuilding or a single-family or duplex residence. You may install electrical wiring in a commercial building the aggregate construction costs of which are under \$75,000. The home or building must be for your own use and occupancy. It may not be built for sale or lease. If you sell or lease more than one building you have wired yourself within 1 year after the construction is complete, the law will presume that you built it for sale or lease, which is a violation of this exemption. You may not hire an unlicensed person as your electrical contractor. Your construction shall be done according to building codes and zoning regulations. It is your responsibility to make sure that people employed by you have licenses required by state law and by county or municipal licensing ordinances.

I have read and understand the terms of this disclosure statement and as an owner / builder I agree to abide by these terms.

Owner Signature

Date